

ESP32-C6

esp-dev-kits Documentation



Release master
Espressif Systems
Dec 18, 2024

Table of contents

Table of contents	i
1 ESP32-C6-DevKitC-1	3
1.1 ESP32-C6-DevKitC-1 v1.2	3
1.1.1 Getting Started	3
1.1.2 Hardware Reference	6
1.1.3 Hardware Revision Details	7
1.1.4 Related Documents	8
2 ESP32-C6-DevKitM-1	15
2.1 ESP32-C6-DevKitM-1	15
2.1.1 Getting Started	15
2.1.2 Hardware Reference	18
2.1.3 Hardware Revision Details	20
2.1.4 Related Documents	20
3 Related Documentation and Resources	21
3.1 Related Documentation	21
3.2 Developer Zone	21
3.3 Products	22
3.4 Contact Us	22
4 Disclaimer and Copyright Notice	23

This document provides detailed user guides and examples for ESP32-C6 series development boards.

Note: For the full list of Espressif development boards, please go to [ESP DevKits](#).

ESP32-C6 Development Boards

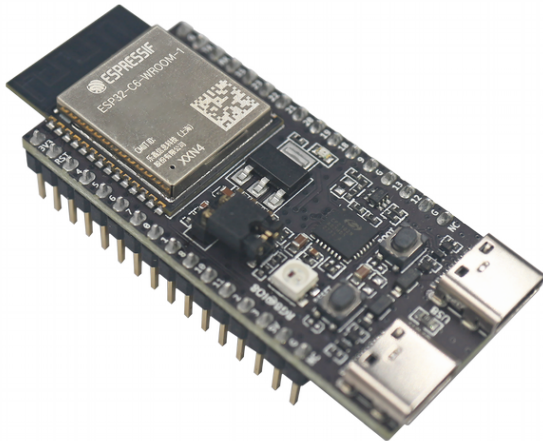

[ESP32-C6-DevKitC-1](#)

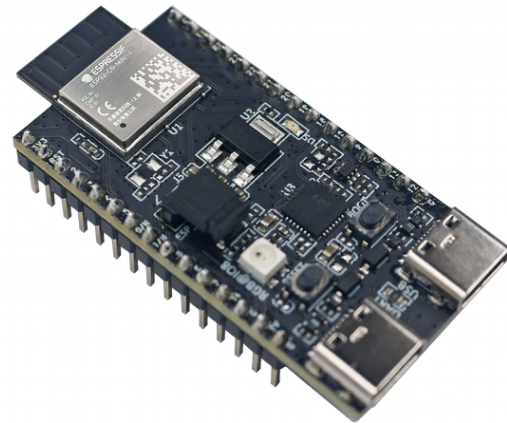

[ESP32-C6-DevKitM-1](#)

Chapter 1

ESP32-C6-DevKitC-1

ESP32-C6-DevKitC-1 is an entry-level development board based on ESP32-C6-WROOM-1(U), a general-purpose module with an 8 MB SPI flash. This board integrates complete Wi-Fi, Bluetooth LE, Zigbee, and Thread functions.

1.1 ESP32-C6-DevKitC-1 v1.2

The older version: [ESP32-C6-DevKitC-1 v1.1](#)

This user guide will help you get started with ESP32-C6-DevKitC-1 and will also provide more in-depth information.

ESP32-C6-DevKitC-1 is an entry-level development board based on [ESP32-C6-WROOM-1\(U\)](#), a general-purpose module with a 8 MB SPI flash. This board integrates complete Wi-Fi, Bluetooth LE, Zigbee, and Thread functions.

Most of the I/O pins are broken out to the pin headers on both sides for easy interfacing. Developers can either connect peripherals with jumper wires or mount ESP32-C6-DevKitC-1 on a breadboard.

The document consists of the following major sections:

- [Getting Started](#): Overview of ESP32-C6-DevKitC-1 and hardware/software setup instructions to get started.
- [Hardware Reference](#): More detailed information about the ESP32-C6-DevKitC-1's hardware.
- [Hardware Revision Details](#): Revision history, known issues, and links to user guides for previous versions (if any) of ESP32-C6-DevKitC-1.
- [Related Documents](#): Links to related documentation.

1.1.1 Getting Started

This section provides a brief introduction of ESP32-C6-DevKitC-1, instructions on how to do the initial hardware setup and how to flash firmware onto it.

Description of Components

The key components of the board are described in a clockwise direction.

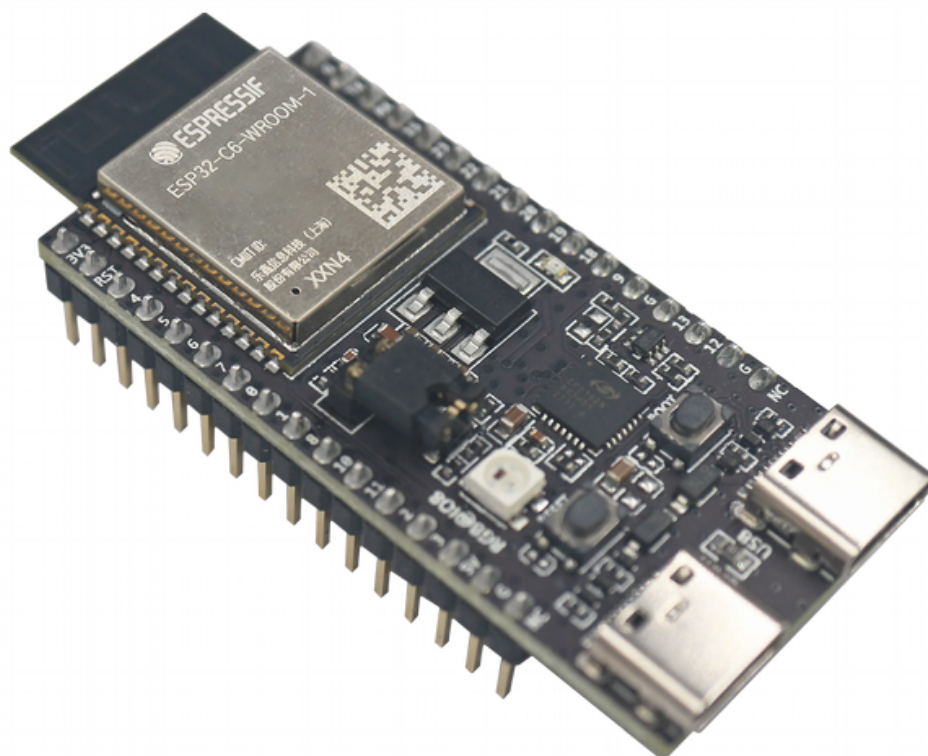

Fig. 1: ESP32-C6-DevKitC-1

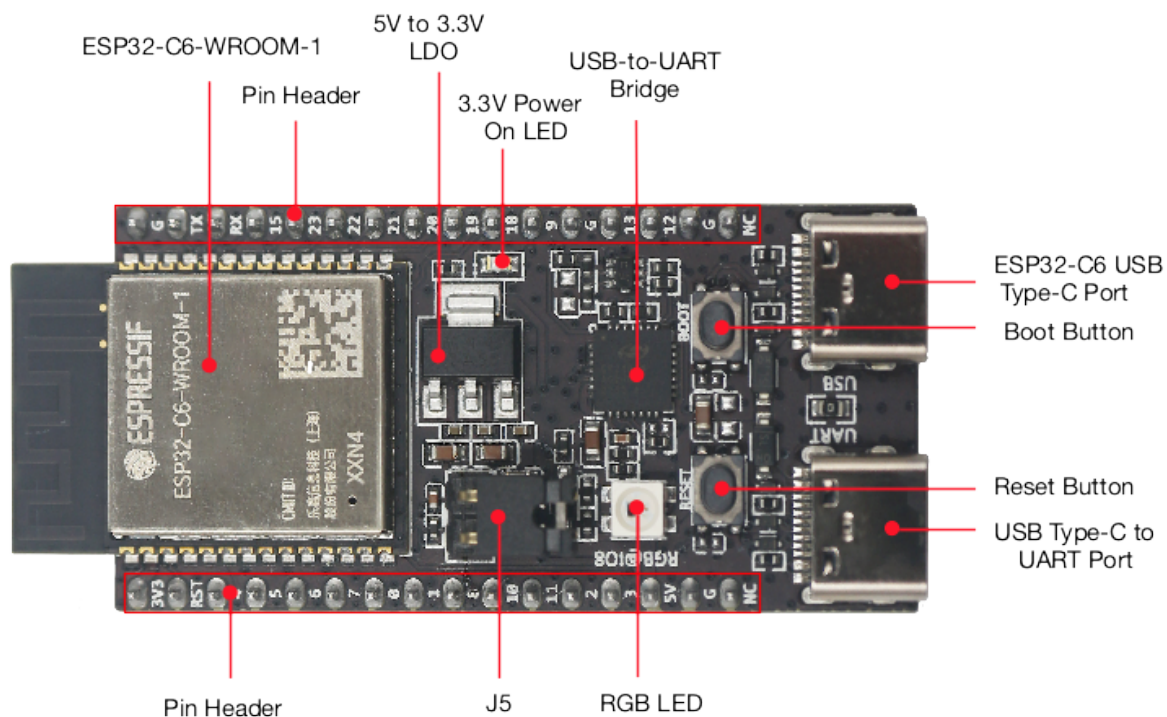

Fig. 2: ESP32-C6-DevKitC-1 - front

Key Component	Description
ESP32-C6-WROOM-1 or ESP32-C6-WROOM-1U	ESP32-C6-WROOM-1 and ESP32-C6-WROOM-1U are general-purpose modules supporting Wi-Fi 6 in 2.4 GHz band, Bluetooth 5, and IEEE 802.15.4 (Zigbee 3.0 and Thread 1.3). They are built around the ESP32-C6 chip, and comes with a 8 MB SPI flash. ESP32-C6-WROOM-1 uses on-board PCB antenna, whereas ESP32-C6-WROOM-1U uses external antenna connector. For more information, see ESP32-C6-WROOM-1 Datasheet .
Pin Header	All available GPIO pins (except for the SPI bus for flash) are broken out to the pin headers on the board.
5 V to 3.3 V LDO	Power regulator that converts a 5 V supply into a 3.3 V output.
3.3 V Power On LED	Turns on when the USB power is connected to the board.
USB-to-UART Bridge	Single USB-to-UART bridge chip provides transfer rates up to 3 Mbps.
ESP32-C6 USB Type-C Port	The USB Type-C port on the ESP32-C6 chip compliant with USB 2.0 full speed. It is capable of up to 12 Mbps transfer speed (Note that this port does not support the faster 480 Mbps high-speed transfer mode). This port is used for power supply to the board, for flashing applications to the chip, for communication with the chip using USB protocols, as well as for JTAG debugging.
Boot Button	Download button. Holding down Boot and then pressing Reset initiates Firmware Download mode for downloading firmware through the serial port.
Reset Button	Press this button to restart the system.
USB Type-C to UART Port	Used for power supply to the board, for flashing applications to the chip, as well as the communication with the ESP32-C6 chip via the on-board USB-to-UART bridge.
RGB LED	Addressable RGB LED, driven by GPIO8.
J5	Used for current measurement. See details in Section Current Measurement .

Start Application Development

Before powering up your ESP32-C6-DevKitC-1, please make sure that it is in good condition with no obvious signs of damage.

Required Hardware

- ESP32-C6-DevKitC-1
- USB-A to USB-C cable
- Computer running Windows, Linux, or macOS

Note: Be sure to use a good quality USB cable. Some cables are for charging only and do not provide the needed data lines nor work for programming the boards.

Software Setup Please proceed to [ESP-IDF Get Started](#), which will quickly help you set up the development environment then flash an application example onto your board.

Contents and Packaging

Retail orders If you order a few samples, each ESP32-C6-DevKitC-1 comes in an individual package in either antistatic bag or any packaging depending on your retailer.

For retail orders, please go to <https://www.espressif.com/en/company/contact/buy-a-sample>.

Wholesale Orders If you order in bulk, the boards come in large cardboard boxes.

For wholesale orders, please check [Espressif Product Ordering Information \(PDF\)](#)

1.1.2 Hardware Reference

Block Diagram

The block diagram below shows the components of ESP32-C6-DevKitC-1 and their interconnections.

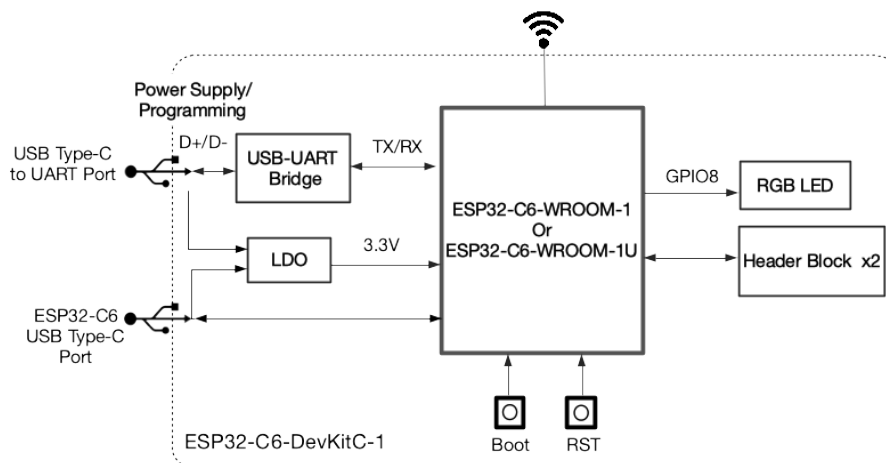

Fig. 3: ESP32-C6-DevKitC-1 (click to enlarge)

Power Supply Options

There are three mutually exclusive ways to provide power to the board:

- USB Type-C to UART Port and ESP32-C6 USB Type-C Port (either one or both), default power supply (recommended)
- 5V and GND pin headers
- 3V3 and GND pin headers

Current Measurement

The J5 headers on ESP32-C6-DevKitC-1 (see J5 in Figure [ESP32-C6-DevKitC-1 - front](#)) can be used for measuring the current drawn by the ESP32-C6-WROOM-1(U) module:

- Remove the jumper: Power supply between the module and peripherals on the board is cut off. To measure the module's current, connect the board with an ammeter via J5 headers.
- Apply the jumper (factory default): Restore the board's normal functionality.

Note: When using 3V3 and GND pin headers to power the board, please remove the J5 jumper, and connect an ammeter in series to the external circuit to measure the module's current.

Header Block

The two tables below provide the **Name** and **Function** of the pin headers on both sides of the board (J1 and J3). The pin header names are shown in Figure [ESP32-C6-DevKitC-1 - front](#). The numbering is the same as in the [ESP32-C6-DevKitC-1 Schematic](#) (PDF).

J1

No.	Name	Type	Function
1	3V3	P	3.3 V power supply
2	RST	I	High: enables the chip; Low: disables the chip.
3	4	I/O/T	MTMS ³ , GPIO4, LP_GPIO4, LP_UART_RXD, ADC1_CH4, FSP1HD
4	5	I/O/T	MTDI ^{Page 7, 3} , GPIO5, LP_GPIO5, LP_UART_TXD, ADC1_CH5, FSP1WP
5	6	I/O/T	MTCK, GPIO6, LP_GPIO6, LP_I2C_SDA, ADC1_CH6, FSP1CLK
6	7	I/O/T	MTDO, GPIO7, LP_GPIO7, LP_I2C_SCL, FSP1D
7	0	I/O/T	GPIO0, XTAL_32K_P, LP_GPIO0, LP_UART_DTRN, ADC1_CH0
8	1	I/O/T	GPIO1, XTAL_32K_N, LP_GPIO1, LP_UART_DSRN, ADC1_CH1
9	8	I/O/T	GPIO8 ^{2Page 7, 3}
10	10	I/O/T	GPIO10
11	11	I/O/T	GPIO11
12	2	I/O/T	GPIO2, LP_GPIO2, LP_UART_RTSN, ADC1_CH2, FSP1Q
13	3	I/O/T	GPIO3, LP_GPIO3, LP_UART_CTSN, ADC1_CH3
14	5V	P	5 V power supply
15	G	G	Ground
16	NC	–	No connection

J3

No.	Name	Type	Function
1	G	G	Ground
2	TX	I/O/T	U0TXD, GPIO16, FSP1CS0
3	RX	I/O/T	U0RXD, GPIO17, FSP1CS1
4	15	I/O/T	GPIO15 ³
5	23	I/O/T	GPIO23, SDIO_DATA3
6	22	I/O/T	GPIO22, SDIO_DATA2
7	21	I/O/T	GPIO21, SDIO_DATA1, FSP1CS5
8	20	I/O/T	GPIO20, SDIO_DATA0, FSP1CS4
9	19	I/O/T	GPIO19, SDIO_CLK, FSP1CS3
10	18	I/O/T	GPIO18, SDIO_CMD, FSP1CS2
11	9	I/O/T	GPIO9 ³
12	G	G	Ground
13	13	I/O/T	GPIO13, USB_D+
14	12	I/O/T	GPIO12, USB_D-
15	G	G	Ground
16	NC	–	No connection

Pin Layout**1.1.3 Hardware Revision Details****ESP32-C6-DevKitC-1 v1.2**

- For boards with the PW number of and after PW-2023-02-0139 (on and after February 2023), J5 is changed from straight headers to curved headers.
- For boards with the PW number of and after PW-2023-07-XXXX (on and after July 2023), multi-point calibration is performed on ADC instead of two-point calibration, and the measurement range and accuracy are

¹ P: Power supply; I: Input; O: Output; T: High impedance.

³ MTMS, MTDI, GPIO8, GPIO9, and GPIO15 are strapping pins of the ESP32-C6 chip. These pins are used to control several chip functions depending on binary voltage values applied to the pins during chip power-up or system reset. For description and application of the strapping pins, please refer to [ESP32-C6 Datasheet](#) > Section *Strapping Pins*.

² Used to drive the RGB LED.

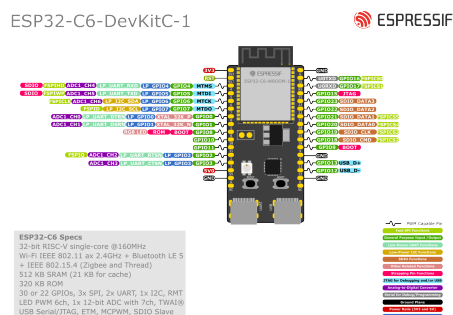

Fig. 4: ESP32-C6-DevKitC-1 Pin Layout (click to enlarge)

illustrated in [ESP32-C6 Datasheet](#) > Section ADC Characteristics. For boards with earlier PW number, please [ask our sales team](#) to provide the actual range and accuracy according to batch.

- For boards with the PW number of and after PW-2023-07-0440 (on and after July 2023), to optimize the WS2812 driving circuit, the resistance of R29 is updated from 4.7 k Ω to 10 k Ω , and the resistance of R6 is updated from 10 k Ω to 3.3 k Ω . For details, see [ESP32-C6-DevKitC-1 Schematic v1.3](#).
- For boards with the PW number of and after PW-2024-03-0595 and PW-2024-03-0921 (on and after March 2024), to optimize the circuit, the resistance of R7 on UART_RXD is updated from 0 Ω to 470 Ω . For details, see [ESP32-C6-DevKitC-1 Schematic v1.4](#).

Note: The PW number can be found in the product label on the large cardboard boxes for wholesale orders.

ESP32-C6-DevKitC-1 v1.1

Initial release

1.1.4 Related Documents

- [ESP32-C6 Datasheet \(PDF\)](#)
- [ESP32-C6-WROOM-1 Datasheet \(PDF\)](#)
- [ESP32-C6-DevKitC-1 Schematic v1.4 \(PDF\)](#) - Applies to boards of and after PW-2024-03-0595 and PW-2024-03-0921
- [ESP32-C6-DevKitC-1 Schematic v1.3 \(PDF\)](#) - Applies to boards of and after PW-2023-07-0440
- [ESP32-C6-DevKitC-1 Schematic v1.2 \(PDF\)](#) - Applies to boards before PW-2023-07-0440
- [ESP32-C6-DevKitC-1 PCB Layout \(PDF\)](#)
- [ESP32-C6-DevKitC-1 Dimensions \(PDF\)](#)
- [ESP32-C6-DevKitC-1 Dimensions source file \(DXF\)](#) - You can view it with [Autodesk Viewer](#) online

For further design documentation for the board, please contact us at sales@espressif.com.

ESP32-C6-DevKitC-1 v1.1

New version available: [ESP32-C6-DevKitC-1 v1.2](#)

This user guide will help you get started with ESP32-C6-DevKitC-1 and will also provide more in-depth information.

ESP32-C6-DevKitC-1 is an entry-level development board based on [ESP32-C6-WROOM-1](#), a general-purpose module with a 8 MB SPI flash. This board integrates complete Wi-Fi, Bluetooth LE, Zigbee, and Thread functions.

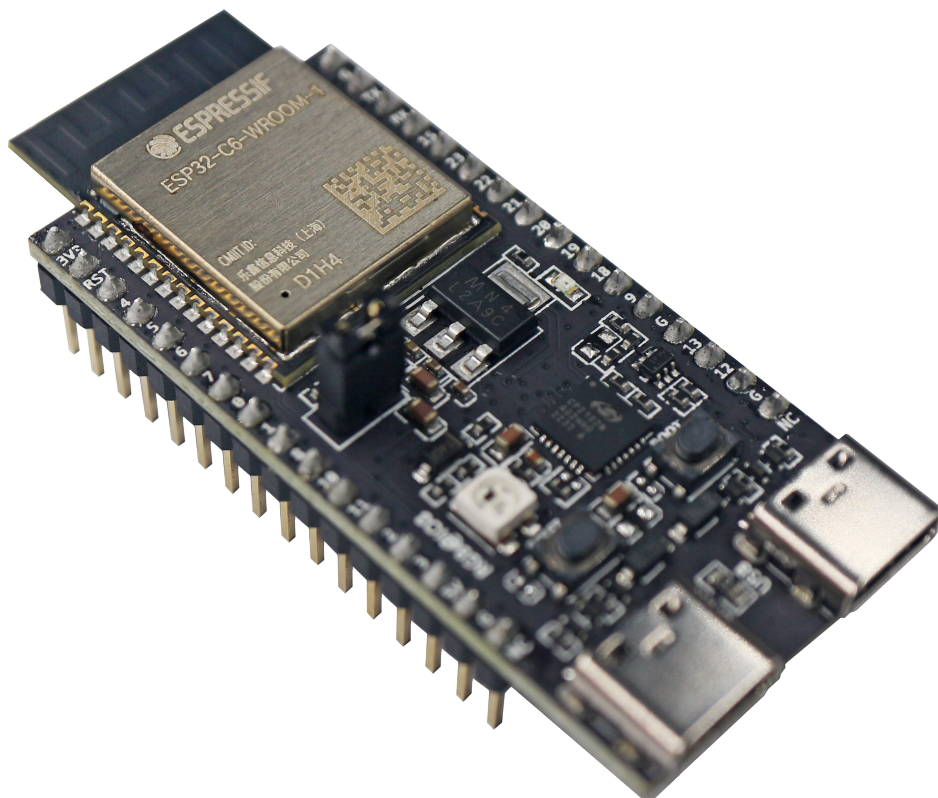

Fig. 5: ESP32-C6-DevKitC-1

Most of the I/O pins are broken out to the pin headers on both sides for easy interfacing. Developers can either connect peripherals with jumper wires or mount ESP32-C6-DevKitC-1 on a breadboard.

The document consists of the following major sections:

- *Getting Started*: Overview of ESP32-C6-DevKitC-1 and hardware/software setup instructions to get started.
- *Hardware Reference*: More detailed information about the ESP32-C6-DevKitC-1's hardware.
- *Hardware Revision Details*: Revision history, known issues, and links to user guides for previous versions (if any) of ESP32-C6-DevKitC-1.
- *Related Documents*: Links to related documentation.

Getting Started This section provides a brief introduction of ESP32-C6-DevKitC-1, instructions on how to do the initial hardware setup and how to flash firmware onto it.

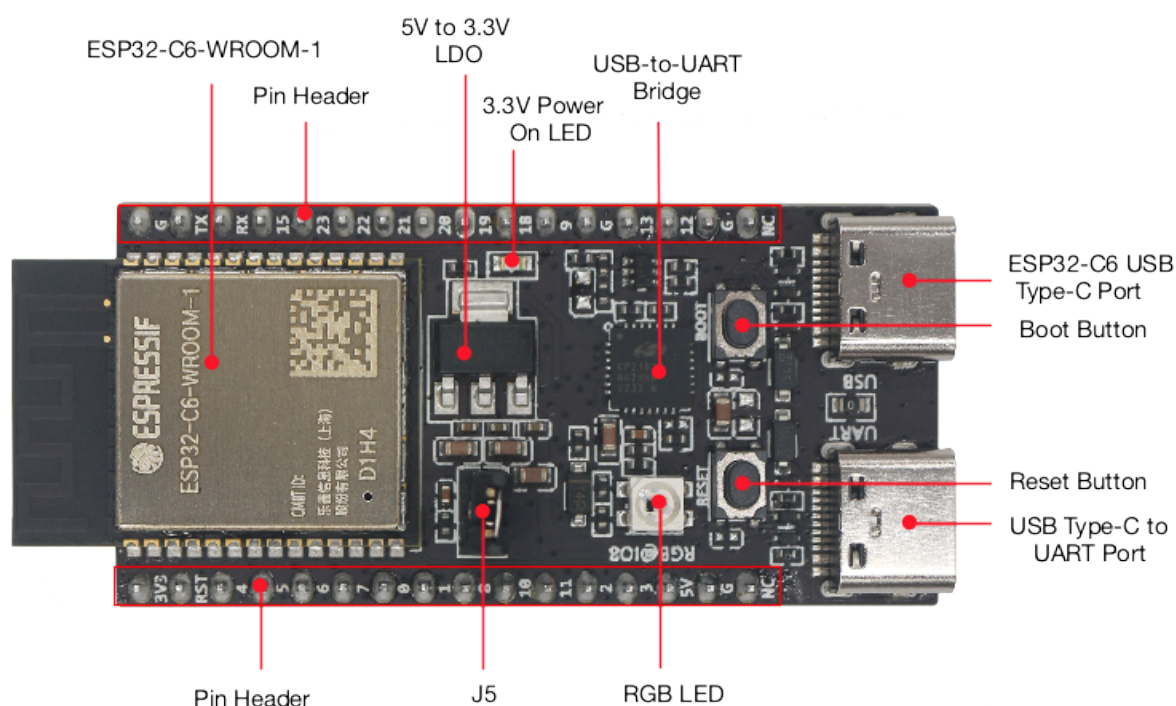

Fig. 6: ESP32-C6-DevKitC-1 - front

Description of Components The key components of the board are described in a clockwise direction.

Key Component	Description
ESP32-C6-WROOM-1	ESP32-C6-WROOM-1 is a general-purpose module supporting Wi-Fi 6 in 2.4 GHz band, Bluetooth 5, and IEEE 802.15.4 (Zigbee 3.0 and Thread 1.3). This module is built around the ESP32-C6 chip, and comes with a PCB antenna and a 8 MB SPI flash. For more information, see ESP32-C6-WROOM-1 Datasheet .
Pin Header	All available GPIO pins (except for the SPI bus for flash) are broken out to the pin headers on the board.
5 V to 3.3 V LDO	Power regulator that converts a 5 V supply into a 3.3 V output.
3.3 V Power On LED	Turns on when the USB power is connected to the board.
USB-to-UART Bridge	Single USB-to-UART bridge chip provides transfer rates up to 3 Mbps.
ESP32-C6 USB Type-C Port	The USB Type-C port on the ESP32-C6 chip compliant with USB 2.0 full speed. It is capable of up to 12 Mbps transfer speed (Note that this port does not support the faster 480 Mbps high-speed transfer mode). This port is used for power supply to the board, for flashing applications to the chip, for communication with the chip using USB protocols, as well as for JTAG debugging.
Boot Button	Download button. Holding down Boot and then pressing Reset initiates Firmware Download mode for downloading firmware through the serial port.
Reset Button	Press this button to restart the system.
USB Type-C to UART Port	Used for power supply to the board, for flashing applications to the chip, as well as the communication with the ESP32-C6 chip via the on-board USB-to-UART bridge.
RGB LED	Addressable RGB LED, driven by GPIO8.
J5	Used for current measurement. See details in Section Current Measurement .

Start Application Development Before powering up your ESP32-C6-DevKitC-1, please make sure that it is in good condition with no obvious signs of damage.

Required Hardware

- ESP32-C6-DevKitC-1
- USB-A to USB-C cable
- Computer running Windows, Linux, or macOS

Note: Be sure to use a good quality USB cable. Some cables are for charging only and do not provide the needed data lines nor work for programming the boards.

Software Setup Please proceed to [ESP-IDF Get Started](#), which will quickly help you set up the development environment then flash an application example onto your board.

Contents and Packaging

Retail orders If you order a few samples, each ESP32-C6-DevKitC-1 comes in an individual package in either antistatic bag or any packaging depending on your retailer.

For retail orders, please go to <https://www.espressif.com/en/company/contact/buy-a-sample>.

Wholesale Orders If you order in bulk, the boards come in large cardboard boxes.

For wholesale orders, please check [Espressif Product Ordering Information](#) (PDF)

Hardware Reference

Block Diagram The block diagram below shows the components of ESP32-C6-DevKitC-1 and their interconnections.

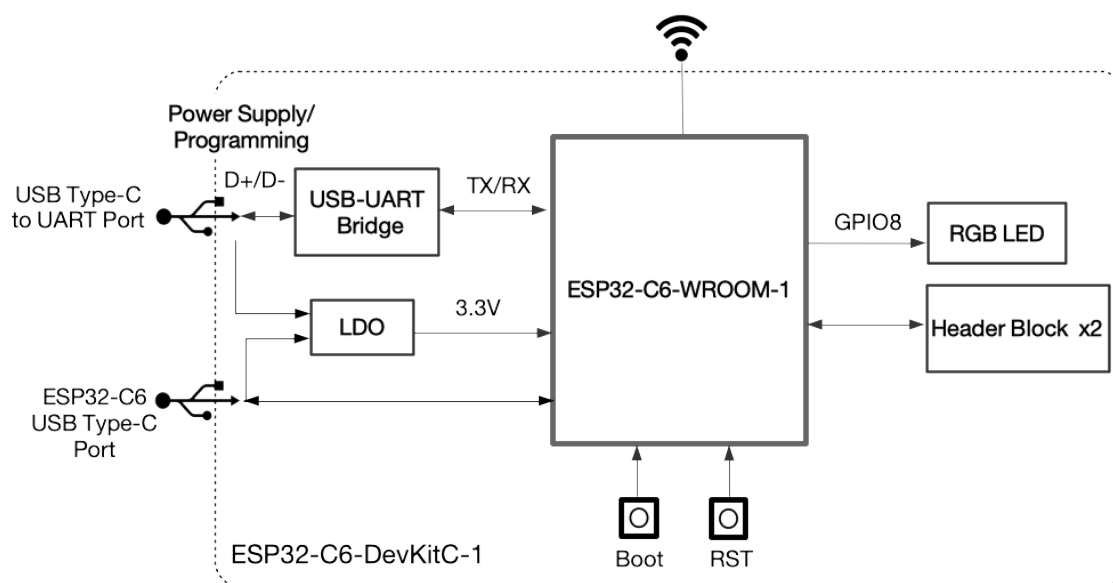

Fig. 7: ESP32-C6-DevKitC-1 (click to enlarge)

Power Supply Options There are three mutually exclusive ways to provide power to the board:

- USB Type-C to UART Port and ESP32-C6 USB Type-C Port (either one or both), default power supply (recommended)
- 5V and GND pin headers
- 3V3 and GND pin headers

Current Measurement The J5 headers on ESP32-C6-DevKitC-1 (see J5 in Figure [ESP32-C6-DevKitC-1 - front](#)) can be used for measuring the current drawn by the ESP32-C6-WROOM-1 module:

- Remove the jumper: Power supply between the module and peripherals on the board is cut off. To measure the module's current, connect the board with an ammeter via J5 headers.
- Apply the jumper (factory default): Restore the board's normal functionality.

Note: When using 3V3 and GND pin headers to power the board, please remove the J5 jumper, and connect an ammeter in series to the external circuit to measure the module's current.

Header Block The two tables below provide the **Name** and **Function** of the pin headers on both sides of the board (J1 and J3). The pin header names are shown in Figure [ESP32-C6-DevKitC-1 - front](#). The numbering is the same as in the [ESP32-C6-DevKitC-1 Schematic](#) (PDF).

J1

No.	Name	Type	Function
1	3V3	P	3.3 V power supply
2	RST	I	High: enables the chip; Low: disables the chip.
3	4	I/O/T	MTMS ³ , GPIO4, LP_GPIO4, LP_UART_RXD, ADC1_CH4, FSPiHD
4	5	I/O/T	MTDI ^{Page 13, 3} , GPIO5, LP_GPIO5, LP_UART_TXD, ADC1_CH5, FSPiWP
5	6	I/O/T	MTCK, GPIO6, LP_GPIO6, LP_I2C_SDA, ADC1_CH6, FSPiCLK
6	7	I/O/T	MTDO, GPIO7, LP_GPIO7, LP_I2C_SCL, FSPiD
7	0	I/O/T	GPIO0, XTAL_32K_P, LP_GPIO0, LP_UART_DTRN, ADC1_CH0
8	1	I/O/T	GPIO1, XTAL_32K_N, LP_GPIO1, LP_UART_DSRN, ADC1_CH1
9	8	I/O/T	GPIO8 ^{2Page 13, 3}
10	10	I/O/T	GPIO10
11	11	I/O/T	GPIO11
12	2	I/O/T	GPIO2, LP_GPIO2, LP_UART_RTSN, ADC1_CH2, FSPiQ
13	3	I/O/T	GPIO3, LP_GPIO3, LP_UART_CTSN, ADC1_CH3
14	5V	P	5 V power supply
15	G	G	Ground
16	NC	–	No connection

J3

No.	Name	Type	Function
1	G	G	Ground
2	TX	I/O/T	U0TXD, GPIO16, FSPiCS0
3	RX	I/O/T	U0RXD, GPIO17, FSPiCS1
4	15	I/O/T	GPIO15 ³
5	23	I/O/T	GPIO23, SDIO_DATA3
6	22	I/O/T	GPIO22, SDIO_DATA2
7	21	I/O/T	GPIO21, SDIO_DATA1, FSPiCS5
8	20	I/O/T	GPIO20, SDIO_DATA0, FSPiCS4
9	19	I/O/T	GPIO19, SDIO_CLK, FSPiCS3
10	18	I/O/T	GPIO18, SDIO_CMD, FSPiCS2
11	9	I/O/T	GPIO9 ³
12	G	G	Ground
13	13	I/O/T	GPIO13, USB_D+
14	12	I/O/T	GPIO12, USB_D-
15	G	G	Ground
16	NC	–	No connection

Pin Layout

Hardware Revision Details No previous versions available.

Related Documents

- [ESP32-C6 Datasheet \(PDF\)](#)
- [ESP32-C6-WROOM-1 Datasheet \(PDF\)](#)
- [ESP32-C6-DevKitC-1 Schematic \(PDF\)](#)
- [ESP32-C6-DevKitC-1 PCB Layout \(PDF\)](#)

¹ P: Power supply; I: Input; O: Output; T: High impedance.

³ MTMS, MTDI, GPIO8, GPIO9, and GPIO15 are strapping pins of the ESP32-C6 chip. These pins are used to control several chip functions depending on binary voltage values applied to the pins during chip power-up or system reset. For description and application of the strapping pins, please refer to [ESP32-C6 Datasheet](#) > Section *Strapping Pins*.

² Used to drive the RGB LED.

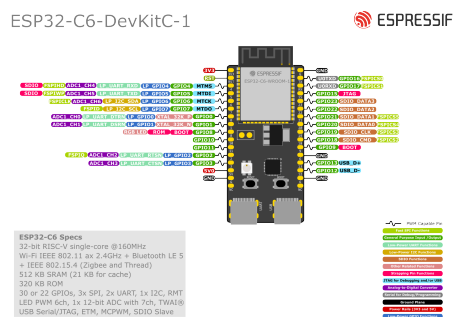

Fig. 8: ESP32-C6-DevKitC-1 Pin Layout (click to enlarge)

- [ESP32-C6-DevKitC-1 Dimensions \(PDF\)](#)
- [ESP32-C6-DevKitC-1 Dimensions source file \(DXF\)](#)

For further design documentation for the board, please contact us at sales@espressif.com.

Chapter 2

ESP32-C6-DevKitM-1

ESP32-C6-DevKitM-1 is an entry-level development board based on ESP32-C6-MINI-1(U), a general-purpose module with a 4 MB SPI flash. This board integrates complete Wi-Fi, Bluetooth LE, Zigbee, and Thread functions.

2.1 ESP32-C6-DevKitM-1

This user guide will help you get started with ESP32-C6-DevKitM-1 and will also provide more in-depth information.

ESP32-C6-DevKitM-1 is an entry-level development board based on [ESP32-C6-MINI-1\(U\)](#), a general-purpose module with a 4 MB SPI flash in the chip's package. This board integrates complete Wi-Fi, Bluetooth LE, Zigbee, and Thread functions.

Most of the I/O pins are broken out to the pin headers on both sides for easy interfacing. Developers can either connect peripherals with jumper wires or mount ESP32-C6-DevKitM-1 on a breadboard.

The document consists of the following major sections:

- *Getting Started*: Overview of ESP32-C6-DevKitM-1 and hardware/software setup instructions to get started.
- *Hardware Reference*: More detailed information about the ESP32-C6-DevKitM-1's hardware.
- *Hardware Revision Details*: Revision history, known issues, and links to user guides for previous versions (if any) of ESP32-C6-DevKitM-1.
- *Related Documents*: Links to related documentation.

2.1.1 Getting Started

This section provides a brief introduction of ESP32-C6-DevKitM-1, instructions on how to do the initial hardware setup and how to flash firmware onto it.

Description of Components

The key components of the board are described in a clockwise direction.

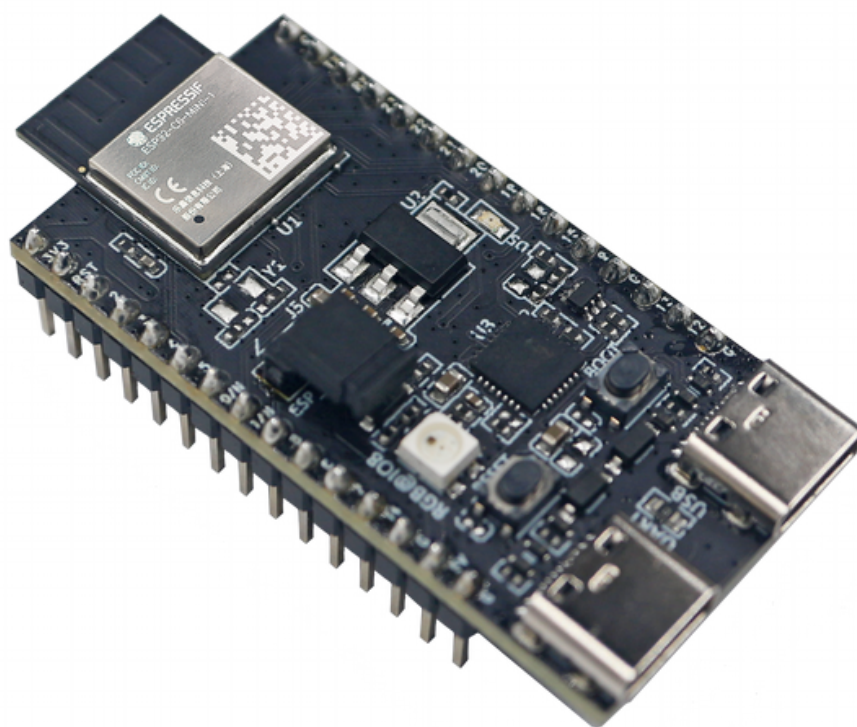

Fig. 1: ESP32-C6-DevKitM-1

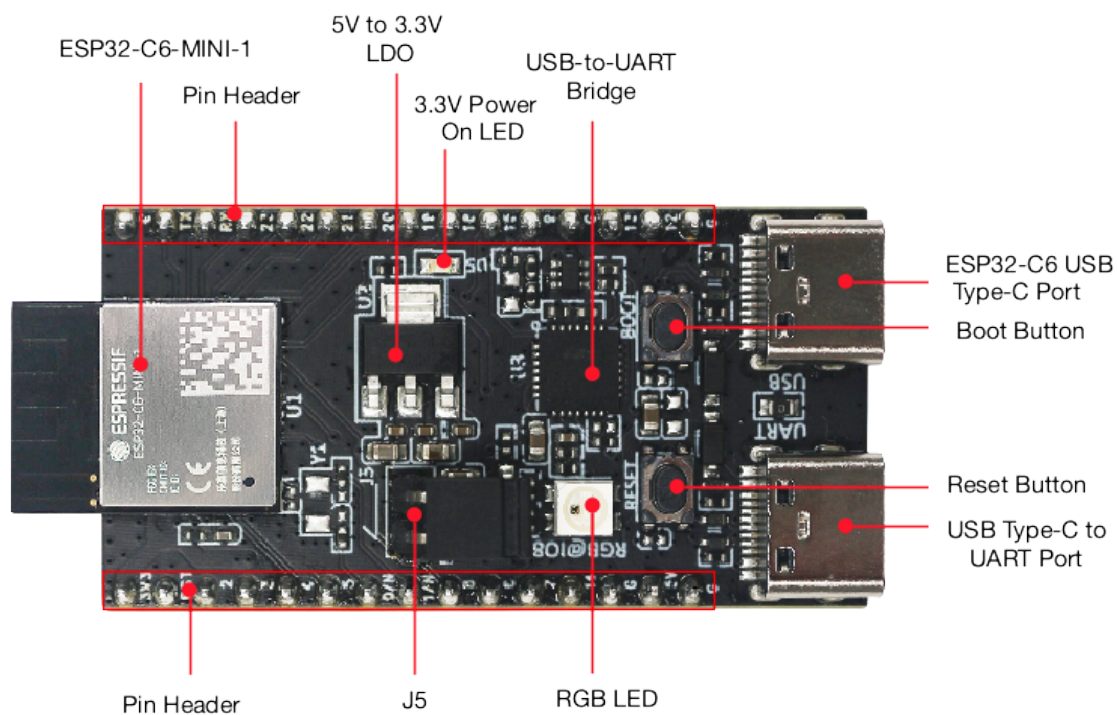

Fig. 2: ESP32-C6-DevKitM-1 - front

Key Component	Description
ESP32-C6-MINI-1 or ESP32-C6-MINI-1U	ESP32-C6-MINI-1 and ESP32-C6-MINI-1U are general-purpose modules supporting Wi-Fi 6 in 2.4 GHz band, Bluetooth 5, and IEEE 802.15.4 (Zigbee 3.0 and Thread 1.3). ESP32-C6-MINI-1 comes with an on-board PCB antenna, whereas ESP32-C6-MINI-1U comes with an external antenna connector. The module is built around the ESP32-C6FH4 chip, which has a 4 MB flash in the chip's package. For more information, see ESP32-C6-MINI-1 Datasheet .
Pin Header	All available GPIO pins (except for the SPI bus for flash) are broken out to the pin headers on the board.
5 V to 3.3 V LDO	Power regulator that converts a 5 V supply into a 3.3 V output.
3.3 V Power On LED	Turns on when the USB power is connected to the board.
USB-to-UART Bridge	Single USB-to-UART bridge chip provides transfer rates up to 3 Mbps.
ESP32-C6 USB Type-C Port	The USB Type-C port on the ESP32-C6 chip compliant with USB 2.0 full speed. It is capable of up to 12 Mbps transfer speed (Note that this port does not support the faster 480 Mbps high-speed transfer mode). This port is used for power supply to the board, for flashing applications to the chip, for communication with the chip using USB protocols, as well as for JTAG debugging.
Boot Button	Download button. Holding down Boot and then pressing Reset initiates Firmware Download mode for downloading firmware through the serial port.
Reset Button	Press this button to restart the system.
USB Type-C to UART Port	Used for power supply to the board, for flashing applications to the chip, as well as the communication with the ESP32-C6 chip via the on-board USB-to-UART bridge.
RGB LED	Addressable RGB LED, driven by GPIO8.
J5	Used for current measurement. See details in Section Current Measurement .

Start Application Development

Before powering up your ESP32-C6-DevKitM-1, please make sure that it is in good condition with no obvious signs of damage.

Required Hardware

- ESP32-C6-DevKitM-1
- USB-A to USB-C cable
- Computer running Windows, Linux, or macOS

Note: Be sure to use a good quality USB cable. Some cables are for charging only and do not provide the needed data lines nor work for programming the boards.

Software Setup Please proceed to [ESP-IDF Get Started](#), which will quickly help you set up the development environment then flash an application example onto your board.

Contents and Packaging

Retail orders If you order a few samples, each ESP32-C6-DevKitM-1 comes in an individual package in either antistatic bag or any packaging depending on your retailer.

For retail orders, please go to <https://www.espressif.com/en/company/contact/buy-a-sample>.

Wholesale Orders If you order in bulk, the boards come in large cardboard boxes.

For wholesale orders, please check [Espressif Product Ordering Information](#) (PDF)

2.1.2 Hardware Reference

Block Diagram

The block diagram below shows the components of ESP32-C6-DevKitM-1 and their interconnections.

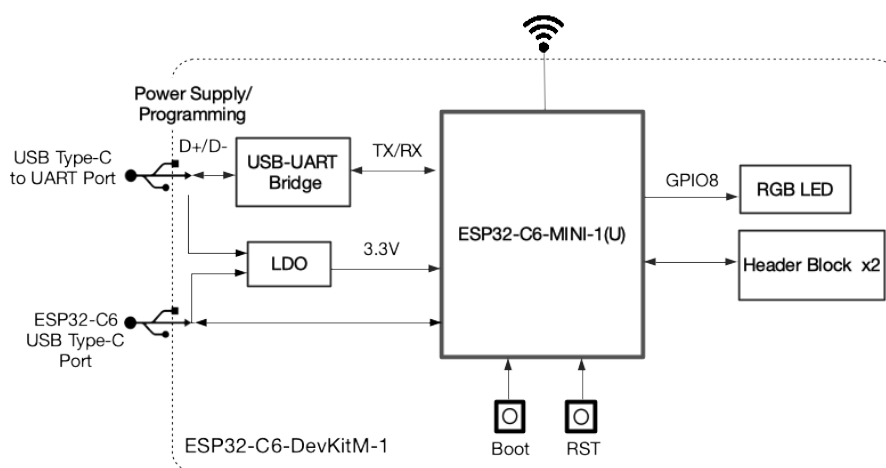

Fig. 3: ESP32-C6-DevKitM-1 (click to enlarge)

Power Supply Options

There are three mutually exclusive ways to provide power to the board:

- USB Type-C to UART Port and ESP32-C6 USB Type-C Port (either one or both), default power supply (recommended)
- 5V and GND pin headers
- 3V3 and GND pin headers

Current Measurement

The J5 headers on ESP32-C6-DevKitM-1 (see J5 in Figure [ESP32-C6-DevKitM-1 - front](#)) can be used for measuring the current drawn by the ESP32-C6-MINI-1(U) module:

- Remove the jumper: Power supply between the module and peripherals on the board is cut off. To measure the module's current, connect the board with an ammeter via J5 headers.
- Apply the jumper (factory default): Restore the board's normal functionality.

Note: When using 3V3 and GND pin headers to power the board, please remove the J5 jumper, and connect an ammeter in series to the external circuit to measure the module's current.

Header Block

The two tables below provide the **Name** and **Function** of the pin headers on both sides of the board (J1 and J3). The pin header names are shown in Figure [ESP32-C6-DevKitM-1 - front](#). The numbering is the same as in the [ESP32-C6-DevKitM-1 Schematic](#) (PDF).

J1

No.	Name	Type	Function
1	3V3	P	3.3 V power supply
2	RST	I	High: Power up; Low: Power down.
3	2	I/O/T	GPIO2, LP_GPIO2, LP_UART_RTSN, ADC1_CH2, FSPIQ
4	3	I/O/T	GPIO3, LP_GPIO3, LP_UART_CTSN, ADC1_CH3
5	4	I/O/T	MTMS ³ , GPIO4, LP_GPIO4, LP_UART_RXD, ADC1_CH4, FSPiHD
6	5	I/O/T	MTDI ^{Page 19, 3} , GPIO5, LP_GPIO5, LP_UART_TXD, ADC1_CH5, FSPiWP
7	0/N	I/O/T	GPIO0, XTAL_32K_P, LP_GPIO0, LP_UART_DTRN, ADC1_CH0
8	1/N	I/O/T	GPIO1, XTAL_32K_N, LP_GPIO1, LP_UART_DSRN, ADC1_CH1
9	8	I/O/T	GPIO8 ^{2Page 19, 3}
10	6	I/O/T	MTCK, GPIO6, LP_GPIO6, LP_I2C_SDA, ADC1_CH6, FSPiCLK
11	7	I/O/T	MTDO, GPIO7, LP_GPIO7, LP_I2C_SCL, FSPiD
12	14	I/O/T	GPIO14
13	G	G	Ground
14	5V	P	5 V power supply
15	G	G	Ground

J3

No.	Name	Type	Function
1	G	G	Ground
2	TX	I/O/T	U0TXD, GPIO16, FSPiCS0
3	RX	I/O/T	U0RXD, GPIO17, FSPiCS1
4	23	I/O/T	GPIO23, SDIO_DATA3
5	22	I/O/T	GPIO22, SDIO_DATA2
6	21	I/O/T	GPIO21, SDIO_DATA1, FSPiCS5
7	20	I/O/T	GPIO20, SDIO_DATA0, FSPiCS4
8	19	I/O/T	GPIO19, SDIO_CLK, FSPiCS3
9	18	I/O/T	GPIO18, SDIO_CMD, FSPiCS2
10	15	I/O/T	GPIO15 ³
11	9	I/O/T	GPIO9 ³
12	G	G	Ground
13	13	I/O/T	GPIO13, USB_D+
14	12	I/O/T	GPIO12, USB_D-
15	G	G	Ground

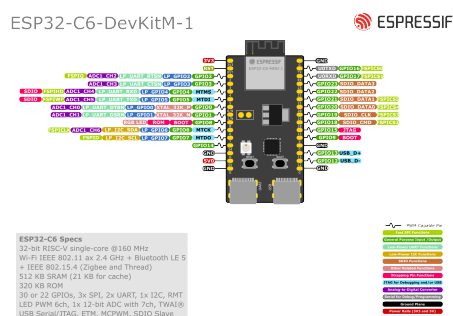

Fig. 4: ESP32-C6-DevKitM-1 Pin Layout (click to enlarge)

¹ P: Power supply; I: Input; O: Output; T: High impedance.

³ MTMS, MTDI, GPIO8, GPIO9, and GPIO15 are strapping pins of the ESP32-C6 chip. These pins are used to control several chip functions depending on binary voltage values applied to the pins during chip power-up or system reset. For description and application of the strapping pins, please refer to [ESP32-C6 Datasheet](#) > Section *Strapping Pins*.

² Used to drive the RGB LED.

Pin Layout

2.1.3 Hardware Revision Details

- For boards with the PW number of and after PW-2023-06-XXXX (on and after June 2023), multi-point calibration is performed on ADC instead of two-point calibration, and the measurement range and accuracy are illustrated in [ESP32-C6 Datasheet](#) > Section ADC Characteristics. For boards with earlier PW number, please [ask our sales team](#) to provide the actual range and accuracy according to batch.

Note: The PW number can be found in the product label on the large cardboard boxes for wholesale orders.

2.1.4 Related Documents

- [ESP32-C6 Datasheet \(PDF\)](#)
- [ESP32-C6-MINI-1 Datasheet \(PDF\)](#)
- [ESP32-C6-DevKitM-1 Schematic \(PDF\)](#)
- [ESP32-C6-DevKitM-1 PCB Layout \(PDF\)](#)
- [ESP32-C6-DevKitM-1 Dimensions \(PDF\)](#)
- [ESP32-C6-DevKitM-1 Dimensions source file \(DXF\)](#) - You can view it with [Autodesk Viewer](#) online

For further design documentation for the board, please contact us at sales@espressif.com.

Chapter 3

Related Documentation and Resources

3.1 Related Documentation

- [ESP32-C6 Datasheet](#) –Specifications of the ESP32-C6 hardware.
- [ESP32-C6 Technical Reference Manual](#) –Detailed information on how to use the ESP32-C6 memory and peripherals.
- [ESP32-C6 Hardware Design Guidelines](#) –Guidelines on how to integrate the ESP32-C6 into your hardware product.
- [ESP32-C6 Product/Process Change Notifications \(PCN\)](#)
<https://espressif.com/en/support/documents/pcns?keys=ESP32-C6>
- [ESP32-C6 Advisories](#) –Information on security, bugs, compatibility, component reliability.
<https://espressif.com/en/support/documents/advisories?keys=ESP32-C6>
- [Certificates](#)
<https://espressif.com/en/support/documents/certificates>
- [Documentation Updates and Update Notification Subscription](#)
<https://espressif.com/en/support/download/documents>

3.2 Developer Zone

- [ESP-IDF Programming Guide for ESP32-C6](#) –Extensive documentation for the ESP-IDF development framework.
- [ESP-IoT-Solution Programming Guide](#) - Extensive documentation for the ESP-IoT-Solution development framework.
- [ESP-FAQ](#) - A summary document of frequently asked questions released by Espressif.
- [ESP-IDF and other development frameworks on GitHub](#).
<https://github.com/espressif>
- [ESP32 BBS Forum](#) –Engineer-to-Engineer (E2E) Community for Espressif products where you can post questions, share knowledge, explore ideas, and help solve problems with fellow engineers.
<https://esp32.com/>
- [The ESP Journal](#) –Best Practices, Articles, and Notes from Espressif folks.
<https://blog.espressif.com/>
- [See the tabs SDKs and Demos, Apps, Tools, AT Firmware](#).
<https://espressif.com/en/support/download/sdks-demos>

3.3 Products

- ESP32-C6 Series SoCs –Browse through all ESP32-C6 SoCs.
<https://espressif.com/en/products/socs?id=ESP32-C6>
- ESP32-C6 Series Modules –Browse through all ESP32-C6-based modules.
<https://espressif.com/en/products/modules?id=ESP32-C6>
- ESP32-C6 Series DevKits –Browse through all ESP32-C6-based devkits.
<https://espressif.com/en/products/devkits?id=ESP32-C6>
- ESP Product Selector –Find an Espressif hardware product suitable for your needs by comparing or applying filters.
<https://products.espressif.com/#/product-selector>

3.4 Contact Us

- See the tabs Sales Questions, Technical Enquiries, Circuit Schematic & PCB Design Review, Get Samples (Online stores), Become Our Supplier, Comments & Suggestions.
<https://espressif.com/en/contact-us/sales-questions>

Chapter 4

Disclaimer and Copyright Notice

Information in this document, including URL references, is subject to change without notice.

All third party's information in this document is provided as is with no warranties to its authenticity and accuracy.

No warranty is provided to this document for its merchantability, non-infringement, fitness for any particular purpose, nor does any warranty otherwise arising out of any proposal, specification or sample.

All liability, including liability for infringement of any proprietary rights, relating to use of information in this document is disclaimed. No licenses express or implied, by estoppel or otherwise, to any intellectual property rights are granted herein.

The Wi-Fi Alliance Member logo is a trademark of the Wi-Fi Alliance. The Bluetooth logo is a registered trademark of Bluetooth SIG.

All trade names, trademarks and registered trademarks mentioned in this document are property of their respective owners, and are hereby acknowledged.