

ESP32-C61

esp-dev-kits Documentation



Release master
Espressif Systems
Apr 27, 2025

Table of contents

Table of contents	i
1 ESP32-C61-DevKitC-1	3
1.1 ESP32-C61-DevKitC-1	3
1.1.1 Getting Started	3
1.1.2 Hardware Reference	6
1.1.3 Hardware Revision Details	8
1.1.4 Related Documents	8
2 Related Documentation and Resources	11
2.1 Developer Zone	11
2.2 Products	11
2.3 Contact Us	11
3 Disclaimer and Copyright Notice	13

This document provides detailed user guides and examples for ESP32-C61 series development boards.

Note: For the full list of Espressif development boards, please go to [ESP DevKits](#).

Chapter 1

ESP32-C61-DevKitC-1

ESP32-C61-DevKitC-1 is an entry-level development board based on ESP32-C61-WROOM-1, a general-purpose module featuring up to 8 MB SPI flash and 2 MB PSRAM. This board integrates complete Wi-Fi and Bluetooth® Low Energy functions.

1.1 ESP32-C61-DevKitC-1

This user guide will help you get started with ESP32-C61-DevKitC-1 and will also provide more in-depth information.

ESP32-C61-DevKitC-1 is an entry-level development board based on ESP32-C61-WROOM-1, a general-purpose module with up to 8 MB SPI flash and 2 MB PSRAM. This board integrates complete Wi-Fi, and Bluetooth® Low Energy functions.

Most of the I/O pins are broken out to the pin headers on both sides for easy interfacing. Developers can either connect peripherals with jumper wires or mount ESP32-C61-DevKitC-1 on a breadboard.

The document consists of the following major sections:

- *Getting Started*: Overview of ESP32-C61-DevKitC-1 and hardware/software setup instructions to get started.
- *Hardware Reference*: More detailed information about the ESP32-C61-DevKitC-1's hardware.
- *Hardware Revision Details*: Revision history, known issues, and links to user guides for previous versions (if any) of ESP32-C61-DevKitC-1.
- *Related Documents*: Links to related documentation.

1.1.1 Getting Started

This section provides a brief introduction of ESP32-C61-DevKitC-1, instructions on how to do the initial hardware setup and how to flash firmware onto it.

Description of Components

The key components of the board are described in a clockwise direction.

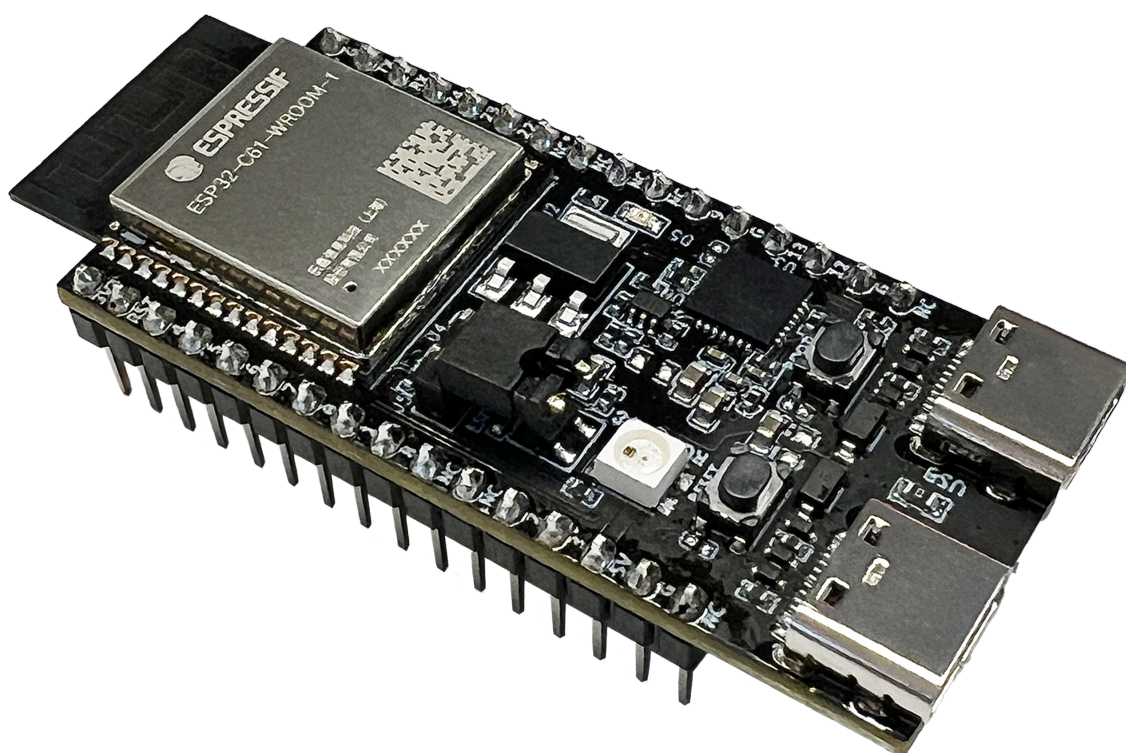

Fig. 1: ESP32-C61-DevKitC-1 (click to enlarge)

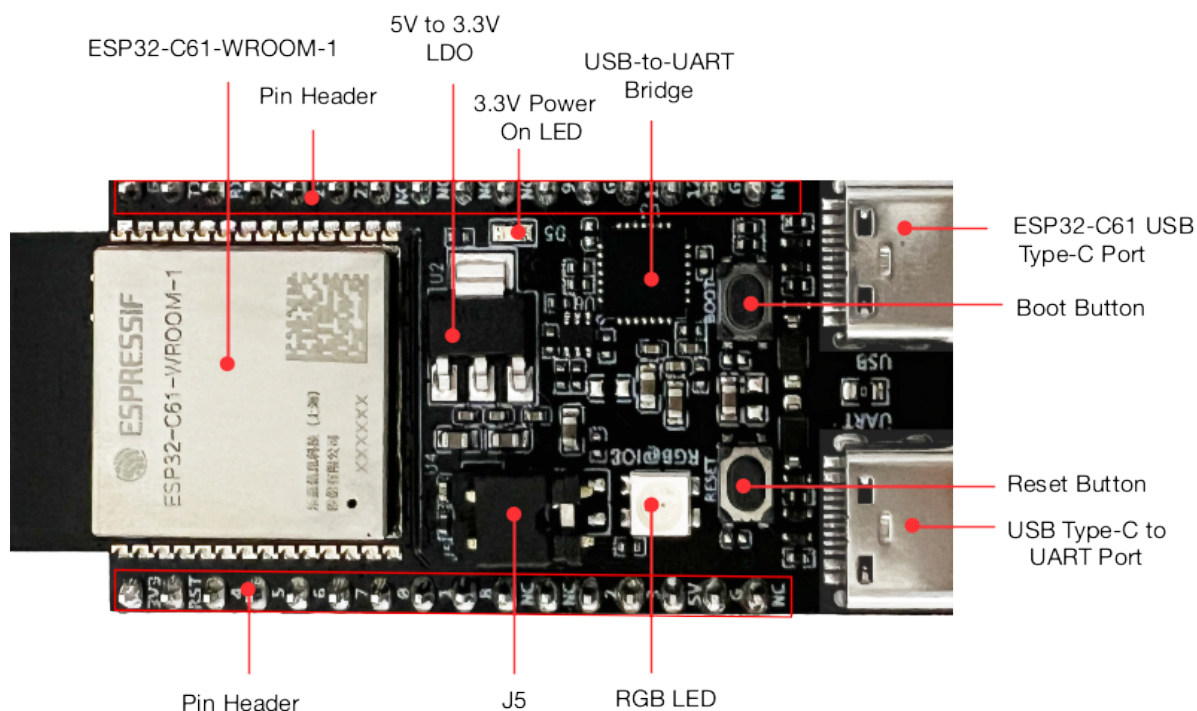

Fig. 2: ESP32-C61-DevKitC-1 - front

Key Component	Description
ESP32-C61-WROOM-1	ESP32-C61-WROOM-1 is a general-purpose module supporting Wi-Fi 6 in 2.4 GHz band and Bluetooth 5. Built around the ESP32-C61HR2 chip, this module comes with a PCB antenna and offers up to 8 MB SPI flash and 2 MB PSRAM.
Pin Header	All available GPIO pins (except for the SPI bus for flash and PSRAM) are broken out to the pin headers on the board.
5 V to 3.3 V LDO	Power regulator that converts a 5 V supply into a 3.3 V output.
3.3 V Power On LED	Turns on when the USB power is connected to the board.
USB-to-UART Bridge	Single USB-to-UART bridge chip provides transfer rates up to 3 Mbps.
ESP32-C61 USB Type-C Port	The USB Type-C port on the ESP32-C61 chip compliant with USB 2.0 full speed. It is capable of up to 12 Mbps transfer speed (Note that this port does not support the faster 480 Mbps high-speed transfer mode). This port is used for power supply to the board, for flashing applications to the chip, for communication with the chip using USB protocols, as well as for JTAG debugging.
Boot Button	Download button. Holding down Boot and then pressing Reset initiates Firmware Download mode for downloading firmware through the serial port.
Reset Button	Press this button to restart the system.
USB Type-C to UART Port	Used for power supply to the board, flashing applications to the chip, as well as communication with the ESP32-C61 chip via the on-board USB-to-UART bridge.
RGB LED	Addressable RGB LED, driven by GPIO8.
J5	Used for current measurement. See details in Section Current Measurement .

Start Application Development

Before powering up your ESP32-C61-DevKitC-1, please make sure that it is in good condition with no obvious signs of damage.

Required Hardware

- ESP32-C61-DevKitC-1
- USB-A to USB-C cable
- Computer running Windows, Linux, or macOS

Note: Be sure to use a good quality USB cable. Some cables are for charging only and do not provide the needed data lines nor work for programming the boards.

Software Setup Please proceed to [ESP-IDF Get Started](#), which will quickly help you set up the development environment then flash an application example onto your board.

Contents and Packaging

Retail orders If you order a few samples, each ESP32-C61-DevKitC-1 comes in an individual package in either antistatic bag or any packaging depending on your retailer.

For retail orders, please go to <https://www.espressif.com/en/company/contact/buy-a-sample>.

Wholesale Orders If you order in bulk, the boards come in large cardboard boxes.

For wholesale orders, please go to <https://www.espressif.com/en/contact-us/sales-questions>. You can also check [Espressif Product Ordering Information \(PDF\)](#).

1.1.2 Hardware Reference

Block Diagram

The block diagram below shows the components of ESP32-C61-DevKitC-1 and their interconnections.

Power Supply Options

There are three mutually exclusive ways to provide power to the board:

- USB Type-C to UART Port and ESP32-C61 USB Type-C Port (either one or both), default power supply (recommended)
- 5V and GND pin headers
- 3V3 and GND pin headers

Current Measurement

The J5 headers on ESP32-C61-DevKitC-1 (see J5 in Figure [ESP32-C61-DevKitC-1 - front](#)) can be used for measuring the current drawn by the ESP32-C61-WROOM-1 module:

- Remove the jumper: Power supply between the module and peripherals on the board is cut off. To measure the module's current, connect the board with an ammeter via J5 headers.
- Apply the jumper (factory default): Restore the board's normal functionality.

Note: When using 3V3 and GND pin headers to power the board, please remove the J5 jumper, and connect an ammeter in series to the external circuit to measure the module's current.

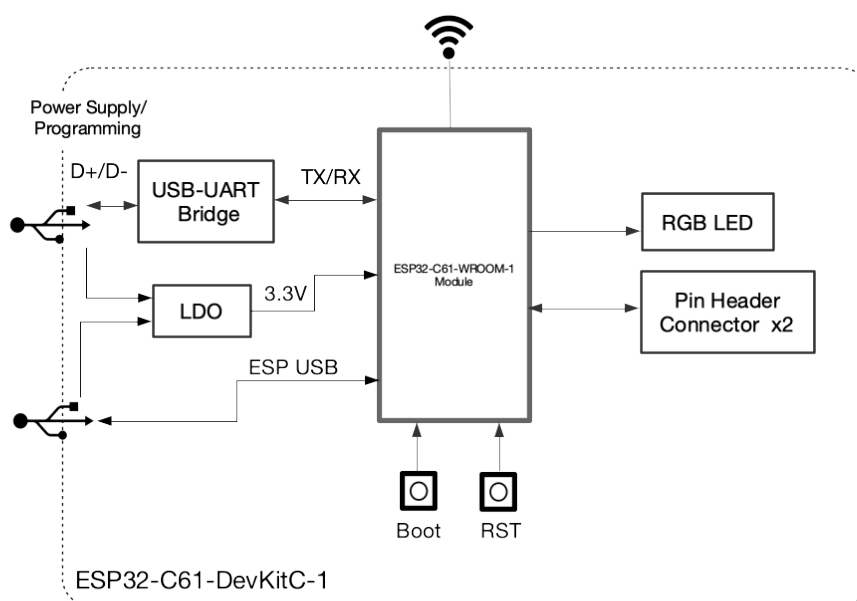

Fig. 3: ESP32-C61-DevKitC-1 (click to enlarge)

Header Block

The two tables below provide the **Name** and **Function** of the pin headers on both sides of the board (J1 and J3). The pin header names are shown in Figure [ESP32-C61-DevKitC-1 - front](#). The numbering is the same as in the [ESP32-C61-DevKitC-1 Schematic \(PDF\)](#).

J1

No.	Name	Type ¹	Function
1	3V3	P	3.3 V power supply
2	RST	I	High: enables the chip; Low: disables the chip.
3	4	I/O/T	MTDI, GPIO4, LP_GPIO4, ADC1_CH2, FSPIWP
4	5	I/O/T	MTCK, GPIO5, LP_GPIO5, ADC1_CH3
5	6	I/O/T	MTDO, GPIO6, LP_GPIO6, FSPICLK
6	7	I/O/T	GPIO7 ³ , FSPID
7	0	I/O/T	GPIO0, XTAL_32K_P, LP_GPIO0
8	1	I/O/T	GPIO1, XTAL_32K_N, LP_GPIO1, ADC1_CH0
9	8	I/O/T	GPIO8 ^{2,3} , ZCD0, FSPICS0
10	NC	–	No connection
11	NC	–	No connection
12	2	I/O/T	GPIO2, LP_GPIO2, FSPIQ
13	3	I/O/T	MTMS, GPIO3, LP_GPIO3, ADC1_CH1, FSPIHD
14	5V	P	5 V power supply
15	G	G	Ground
16	NC	–	No connection

¹ P: Power supply; I: Input; O: Output; T: High impedance.

³ GPIO7, GPIO8, and GPIO9 are strapping pins of the ESP32-C61 chip. These pins are used to control several chip functions depending on binary voltage values applied to the pins during chip power-up or system reset.

² Used to drive the RGB LED.

J3

No.	Name	Type	Function
1	G	G	Ground
2	TX	I/O/T	U0TXD, GPIO11
3	RX	I/O/T	U0RXD, GPIO10
4	24	I/O/T	GPIO24
5	23	I/O/T	GPIO23
6	22	I/O/T	GPIO22
7	NC/14	I/O/T	No connection/GPIO14 ⁴
8	NC	–	No connection
9	NC	–	No connection
10	NC	–	No connection
11	9	I/O/T	GPIO9 ³ , ZCD1
12	G	G	Ground
13	13	I/O/T	GPIO13, USB_D+
14	12	I/O/T	GPIO12, USB_D-
15	G	G	Ground
16	NC	–	No connection

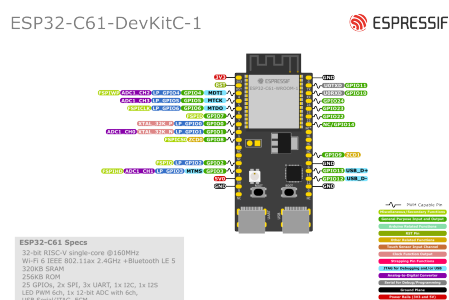

Fig. 4: ESP32-C61-DevKitC-1 Pin Layout (click to enlarge)

Pin Layout

1.1.3 Hardware Revision Details

No previous versions available.

1.1.4 Related Documents

Please download the following documents from [the HTML version of esp-dev-kits Documentation](#).

- [ESP32-C61-DevKitC-1 Schematic \(PDF\)](#)
- [ESP32-C61-DevKitC-1 PCB Layout \(PDF\)](#)
- [ESP32-C61-DevKitC-1 Dimensions \(PDF\)](#)
- [ESP32-C61-DevKitC-1 Dimensions source file \(DXF\)](#)

For further design documentation for the board, please contact us at sales@espressif.com.

⁴ For the module with integrated SPI PSRAM, this pin is already used as SPICS1 and cannot be used for other functions; for the module without integrated SPI PSRAM, this pin can be used as GPIO14.

ESP32-C61 Development Boards

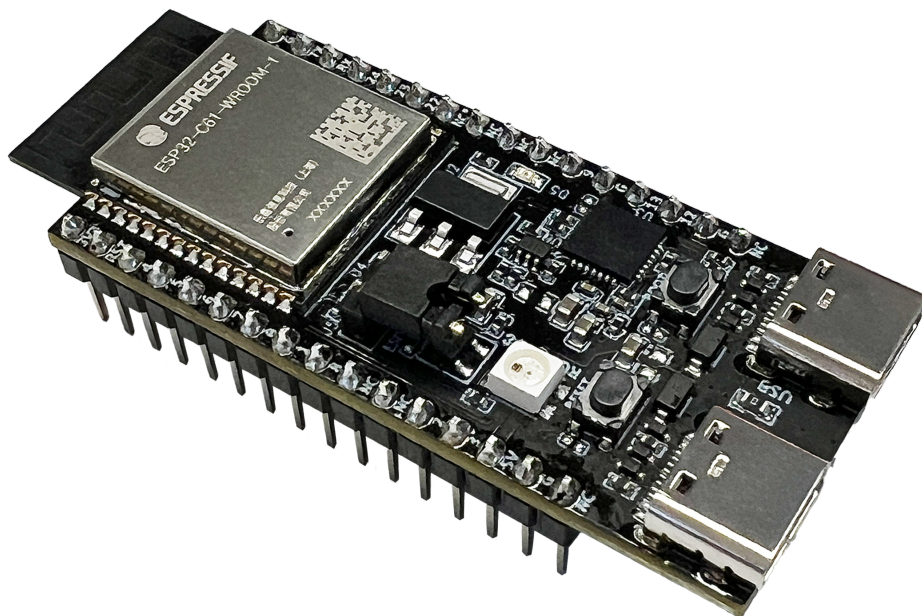

ESP32-C61-DevKitC-1

Chapter 2

Related Documentation and Resources

2.1 Developer Zone

- [ESP-IDF Programming Guide](#) –Extensive documentation for the ESP-IDF development framework.
- [ESP-IoT-Solution Programming Guide](#) - Extensive documentation for the ESP-IoT-Solution development framework.
- [ESP-FAQ](#) - A summary document of frequently asked questions released by Espressif.
- ESP-IDF and other development frameworks on GitHub.
<https://github.com/espressif>
- ESP32 BBS Forum –Engineer-to-Engineer (E2E) Community for Espressif products where you can post questions, share knowledge, explore ideas, and help solve problems with fellow engineers.
<https://esp32.com/>
- The ESP Journal –Best Practices, Articles, and Notes from Espressif folks.
<https://blog.espressif.com/>
- See the tabs SDKs and Demos, Apps, Tools, AT Firmware.
<https://espressif.com/en/support/download/sdks-demos>

2.2 Products

- ESP32-C61 Series SoCs –Browse through all ESP32-C61 SoCs.
<https://espressif.com/en/products/socs?id=ESP32-C61>
- ESP32-C61 Series Modules –Browse through all ESP32-C61-based modules.
<https://espressif.com/en/products/modules?id=ESP32-C61>
- ESP32-C61 Series DevKits –Browse through all ESP32-C61-based devkits.
<https://espressif.com/en/products/devkits?id=ESP32-C61>
- ESP Product Selector –Find an Espressif hardware product suitable for your needs by comparing or applying filters.
<https://products.espressif.com/#/product-selector>

2.3 Contact Us

- See the tabs Sales Questions, Technical Enquiries, Circuit Schematic & PCB Design Review, Get Samples (Online stores), Become Our Supplier, Comments & Suggestions.
<https://espressif.com/en/contact-us/sales-questions>

Chapter 3

Disclaimer and Copyright Notice

Information in this document, including URL references, is subject to change without notice.

All third party's information in this document is provided as is with no warranties to its authenticity and accuracy.

No warranty is provided to this document for its merchantability, non-infringement, fitness for any particular purpose, nor does any warranty otherwise arising out of any proposal, specification or sample.

All liability, including liability for infringement of any proprietary rights, relating to use of information in this document is disclaimed. No licenses express or implied, by estoppel or otherwise, to any intellectual property rights are granted herein.

The Wi-Fi Alliance Member logo is a trademark of the Wi-Fi Alliance. The Bluetooth logo is a registered trademark of Bluetooth SIG.

All trade names, trademarks and registered trademarks mentioned in this document are property of their respective owners, and are hereby acknowledged.