

Design Block:

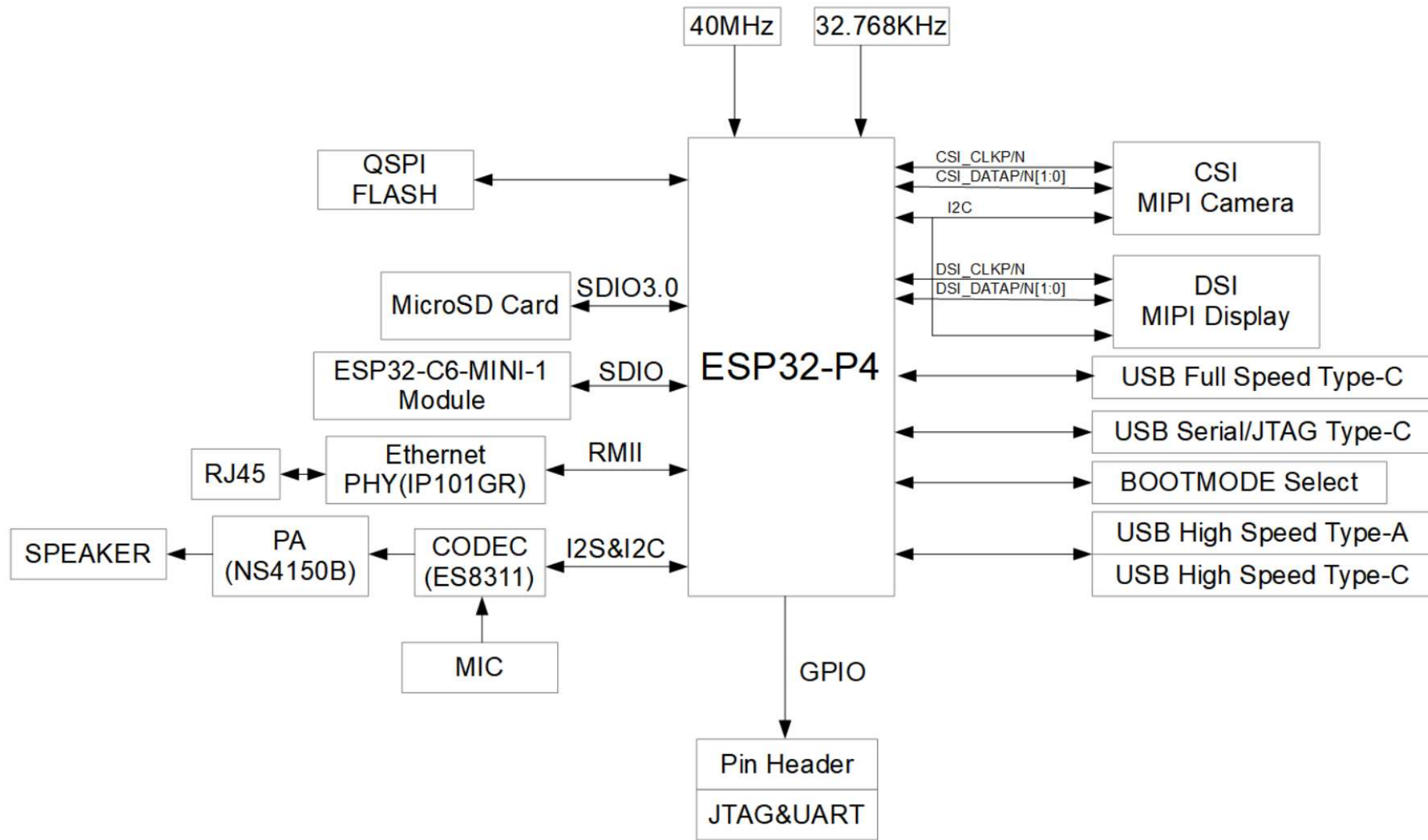

FLASH:

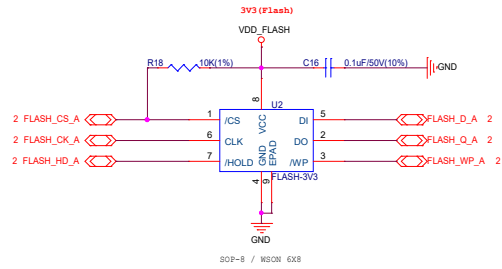

Boot Strapping Pins:

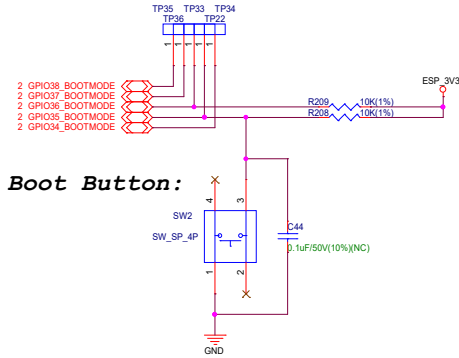

Reset Button:

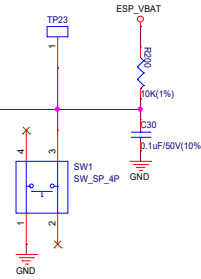

Boot Button:

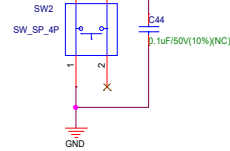

Pin Header For GPIOs:

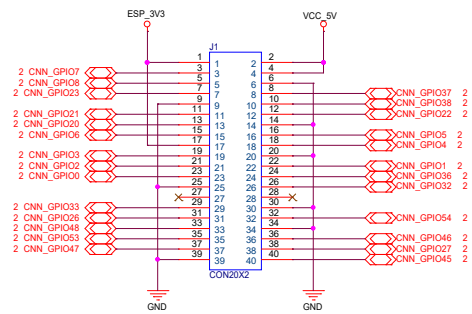

CSI Connector:

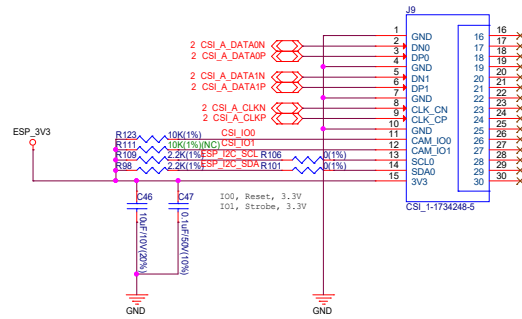

DSI Connector:

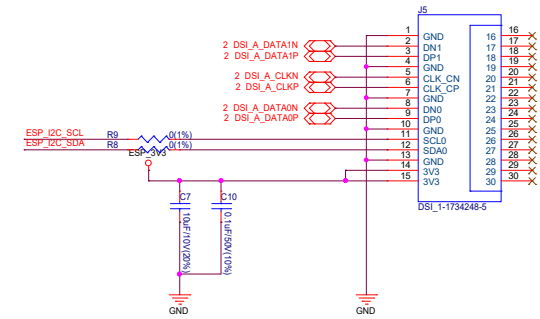

2,4 ESP_I2C_SCL ↔ ESP_I2C_SCL
2,4 ESP_I2C_SDA ↔ ESP_I2C_SDA

USB High Speed & Power in:

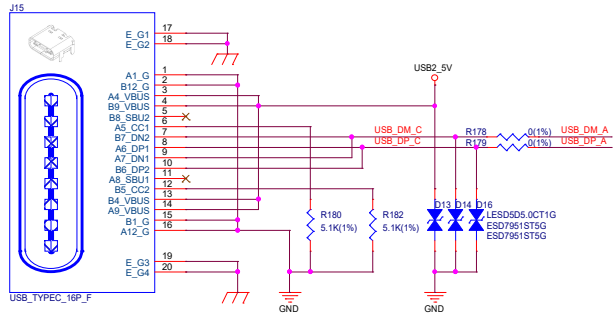

USB Serial/JTAG & Power in:

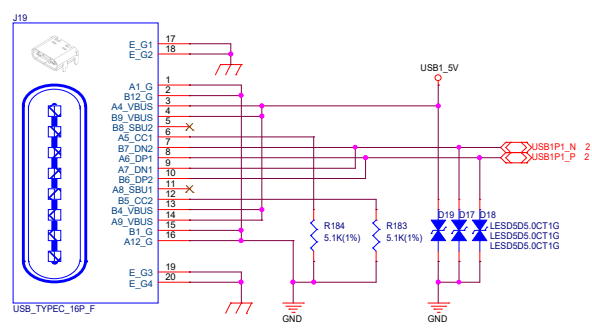

USB Full Speed Slave & Power in:

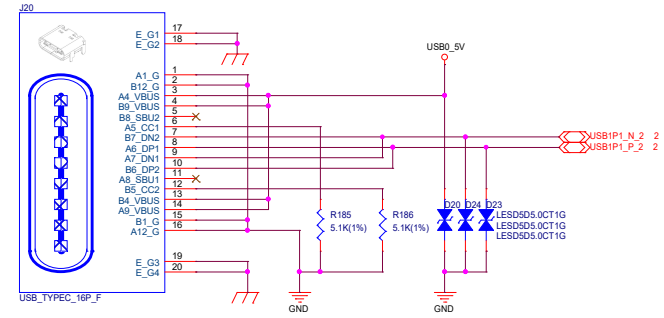

Ideal Diodes:

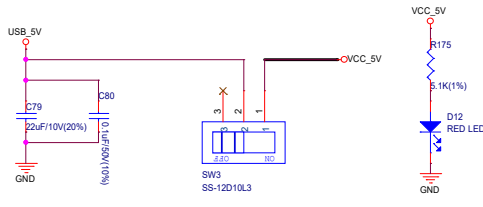
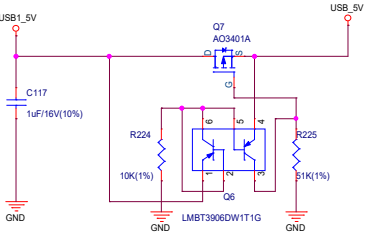
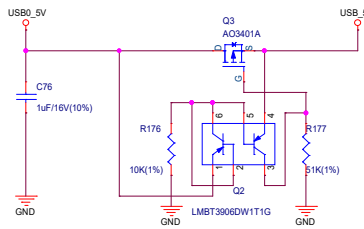
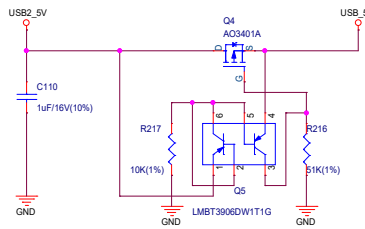

3V3 DC-DC:

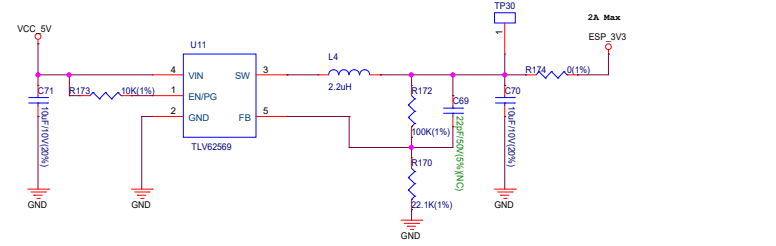

USB High Speed Host:

Jumper@J10

